

HIGHLIFTER

ALIGNMENT TOOL PARTS DIAGRAM

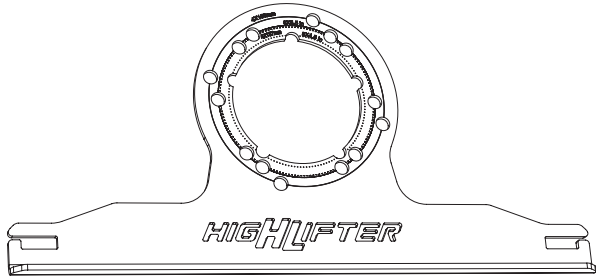

(2) Toe Alignment Plates

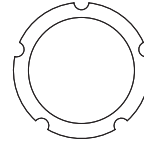

(2) Center Adapters
(For use with 5 Lug Wheels)

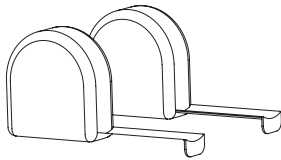

(2) Tape Measures

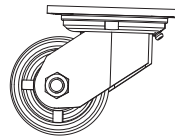

(4) Casters + Hardware Bag

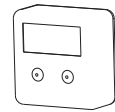

Digital Angle Finder

WARRANTY INFORMATION



HIGH LIFTER LIMITED LIFETIME WARRANTY

High Lifter offers a Limited Lifetime Warranty to the original purchaser that our product shall be free from defects in material and workmanship for the life of the product, if utilized in accordance with the manufacturer's instructions for installation and operation of said products.

Damages to vehicle or any other object during the installation, use, or removal of High Lifter products are **NOT** covered under this warranty. Normal wear items included with any of the products covered under this Limited Lifetime Warranty are excluded from coverage. These items include, but are not limited to heim joints, tie rods, bearings, bushings, seals, gaskets, zinc plating, painted and powder coated finishes. Other exclusions of coverage under this warranty include, but are not limited to: damage or product failure due to improper installation, lack of maintenance, product modification, abuse, collision or use on vehicles for which product was not designed, repairs performed by anyone other than approved High Lifter personnel or made using non-High Lifter components. This warranty is valid for the original purchaser only and is non-transferable. High Lifter reserves the right to inspect any product before determining if the claim is valid and covered under this warranty. Claims determined to be caused by reasons other than a manufacturer defect will be rejected and an estimate for repair or cost of a replacement product if a repair is not possible, will be provided.

This warranty is exclusive and is in lieu of any implied warranty of merchantability, fitness for a particular purpose or other warranty of quality, whether express or implied, except the warranty of title.

**FOR MORE WARRANTY INFORMATION ON THIS PRODUCT, PLEASE VISIT OUR WEBSITE
HIGHLIFTER.COM**

ALIGNMENT TOOL INSTRUCTIONS

STEP 1

INSTALL CASTERS

- Attach casters to the bottom of the alignment plate using the provided hardware.

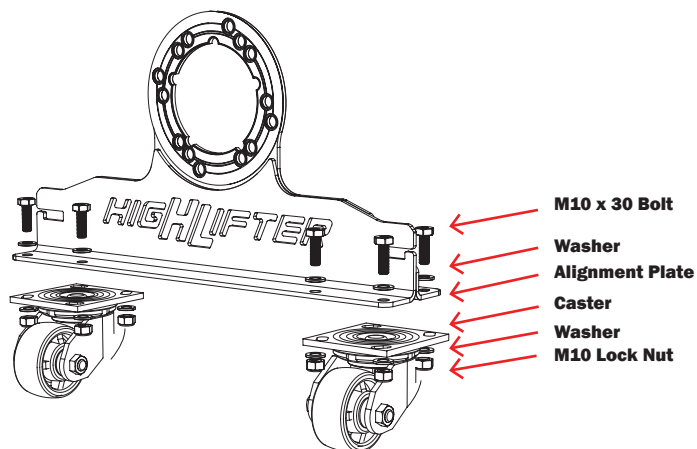

STEP 2

LIFT VEHICLE

- Use a jack or lift to raise vehicle.
- If using a jack, place jack stands of the EXACT same height under vehicle.



STEP 3

WHEEL ALIGNMENT

- Align the wheels as straight as possible.
- It is recommended to do this once the wheels are removed, but can be done before.
- Check steering.



 Some model's steering may NOT be centered causing the tie rod ends to have more engagement on one side. THIS MUST BE CORRECTED IF APPLICABLE TO THE VEHICLE.

STEP 4

REMOVE FRONT WHEELS

- Remove lugs from the wheel.
- Remove tire from hub. Set aside.

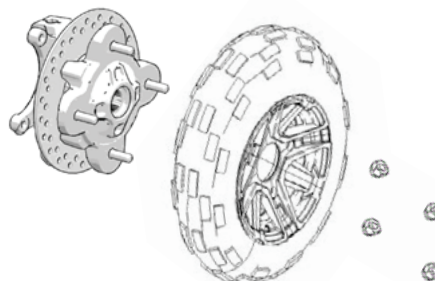

ALIGNMENT TOOL INSTRUCTIONS

STEP 5



CAMBER ADJUSTMENT



IF YOU DO NOT HAVE ADJUSTABLE CONTROL ARMS, SKIP THIS STEP.

CAMBER ADJUSTMENT CHART

Collar Turn	0.5	1	1.5	2	4	6
Adjustment (Degrees)	0.25°	0.5°	0.75°	1°	2°	3°

POSITIVE CAMBER



If you have a positive camber you will need to adjust the collar **OUTWARD** or lengthen the collar. Up to 3° available adjustment outward.

ZERO CAMBER



We recommend a camber setting of 0°. High Lifter collars are preset to .937". This measurement is from the top of the collar's threads, to the bottom of the jam nut.

NEGATIVE CAMBER



If you have a negative camber you will need to adjust the collar **INWARD** or shorten the collar. Up to 3° available adjustment inward.

STEP 6



INSTALL TOOL

- Align tool with the studs on the hub.
- Install the alignment tool to **BOTH** front hubs
- Level tool straight. Rotate hub if needed.
- Secure tool to hubs by fastening lugs.

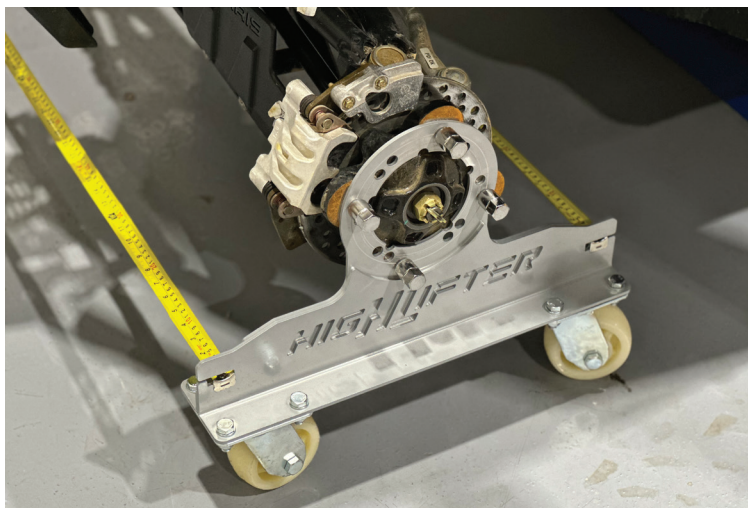

ALIGNMENT TOOL INSTRUCTIONS

STEP 7

TAKE MEASUREMENTS

- Ensure wheel is as straight as possible.
- Place the two measuring tapes on the slotted ends of the alignment tool.
- Measure end-to-end.



STEP 8

LOWER AND REMOVE JACK

- Settle the suspension to full load/ride height.

STEP 9

ADJUST TIE RODS

- Adjust tie rods until **BOTH** measurements are the **SAME**, then adjust toe tolerance.

The recommended vehicle toe tolerance is 1/8" to 1/4" (3.175-6.35mm) toe out. This means the **FRONT MEASUREMENT IS WIDER THAN THE REAR MEASUREMENT.**

TOE ADJUSTMENT CHART

TOE (Inches)	1/16	1/8	3/16	1/4	5/16	3/8
TOE (Degrees)	0.12°	0.25°	0.38°	0.51°	0.64°	0.76°

Recommended Settings

TOE OUT +



If the **FRONT OF THE WHEELS** are facing **OUT**, adjust the tie rods **OUT** or **INCREASE** the length of the tie rod.

Measurement at the front of the tires will be **GREATER** than the rear, if the **TOE IS OUT**.

TOE IN -



If the **FRONT OF THE WHEELS** are facing **IN**, adjust the tie rods **IN** or **REDUCE** the length of the tie rod.

Measurement at the front of the tires will be **LESS** than the rear, if the **TOE IS IN**.